

Specifications

SMART Board™ Interactive Whiteboard

Model SBD680

Physical Specifications

Size	65 1/4" W × 50 5/8" H × 5 1/8" D (165.7 cm × 128.6 cm × 13 cm)
Active Screen Area (maximum interactive, projected image)	61 5/8" W × 46 1/8" H (156.5 cm × 117.2 cm) 77" diagonal (195.6 cm)
FS670 Floor Stand (with SBD680 Installed)	65 1/4" W × 67 7/8" to 81 7/8" H × 40 3/8" D (165.7 cm × 172.4 cm to 208 cm × 102.5 cm)
Weight	30 lb. (13.6 kg)
Shipping Size	
1 unit	73 1/2" W × 54" H × 5 1/2" D (186.7 cm × 137.2 cm × 14 cm)
8 units on pallet	55" W × 78 1/2" H × 45" D (139.7 cm × 199.4 cm × 114.3 cm)
Shipping Weight	
1 unit	45 lb. (20.5 kg)
8 units on pallet	380 lb. (172.7 kg)

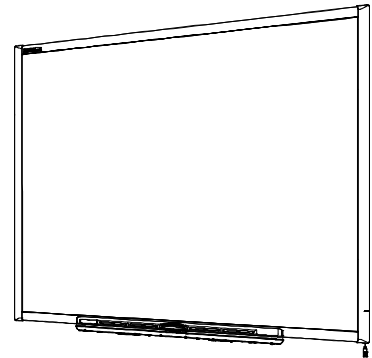

All dimensions +/- 1/8" (0.3 cm). All weights +/- 2 lb. (0.9 kg).

Standard Features

Software	Includes SMART Notebook software. See the SMART Notebook software specifications for a complete list of system requirements. Software upgrades are available from www2.smarttech.com/st/en-US/Support/SBS/ .
Dual Touch/Dual Write	Enables two users to work simultaneously in SMART Notebook software
Pen Tray	Optical sensors in the pen tray detect when you lift one or two pens, or the eraser, from the tray. LEDs indicate the active tools.
Pens and Eraser	Black, red, green and blue pen tray pens and a rectangular eraser
Resolution	Touch resolution is approximately 4000 × 4000.
Screen Surface	The hard-coated surface is tear proof, optimized for projection, compatible with dry-erase markers and cleans easily with whiteboard cleaner.
Digitizing Technology	Resistive technology
Frame Finish	Dark gray (approximates Pantone® Charcoal Gray 18-0601 TPX) and Ultrasonic Chrome (approximates metallic Pantone 877C)
Wall-Mount Bracket	Includes a 32" (81.3 cm) wide bracket, five screws and five drywall anchors to support your wall-mounted interactive whiteboard
Computer Connection	16' (5 m) USB 2.0 cable
Power Requirements	Power is obtained from your computer directly through the USB cable for Windows®, Mac and Linux® computers. Power consumption is less than 1.5 W (300mA at 5V).
Certifications and Compliance	CSA (U.S./Canada), CE, CB (TUV), China EIP, RoHS (Europe) and WEEE
Warranty	Five-year limited equipment warranty upon registration. See included warranty document for details.
Theft Prevention	Features a pen tray locking feature and a Kensington® security slot on the pen tray

NOTE

A digital projector isn't included with this model of SMART Board interactive whiteboard. To take full advantage of all interactive features, you must integrate a digital projector.

Storage and Operating Specifications

Storage	<ul style="list-style-type: none">• Maximum storage temperature: 122°F (50°C)• Minimum storage temperature: -40°F (-40°C)
Operation	41°F to 95°F (5°C to 35°C) with up to 80% humidity, non-condensing

SMART Order Number

SBD680 77" (195.6 cm) diagonal dual-touch SMART Board 680 interactive whiteboard

Optional Accessories

NOTE

The RS-232 to USB conversion module and WC6 wireless Bluetooth® connection option aren't available for this model.

Part Number	Description	NA	UK	EU	AU
FS670	Mobile floor stand with 4" (10.2 cm) lockable casters and flip-up, anti-tip feet				
CCJ680	Padded cover with handles for SMART Board 680 and SBD680 interactive whiteboards				
HSCJ-680	Hard shipping case for SMART Board 680 and SBD680 interactive whiteboards and the FS670 floor stand				
WMCM-680	Wall-mounted cabinet for SMART Board 680 and SBD680 interactive whiteboards				
PMWT-680	Projector wall mount for an NEC WT600 or WT610 projector				
SBA-XX*	USB audio system with two 15 W speakers mounts on your interactive whiteboard or the wall	✓	✓	✓	✓
SYSON6-XX*	SystemOn expansion module wakes up your computer and turns on your projector with one button press	✓	✓		
USB-GW	GoWire™ SMART Notebook software auto-launch cable				
USB-XT	16' (5 m) USB active extension cable				
CAT5-XT	Cat 5 to USB cable extender set				
RPEN-ER	Replacement set of four pen tray pens (black, red, green and blue) and a rectangular eraser				
RPEN	Replacement set of four pen tray pens (black, red, green and blue)				

*Part numbers ending in XX include region-specific power supplies for the countries or regions indicated by ✓ at the right. When ordering, substitute XX in the part number with the appropriate country code, as follows:

- NA = U.S. and Canada
- UK = United Kingdom
- EU = European Union
- AU = Australia

Physical Dimensions

**Wall-Mounted
Cut Away View**

Leave at least 5/8" (1.6 cm) headroom to wall-mount your interactive whiteboard.

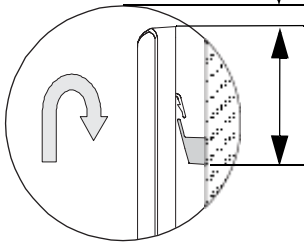

The distance from the bottom of the wall-mount bracket to the top of your installed interactive whiteboard is 4 1/4" (10.8 cm).

**Wall-Mounted
Side View**

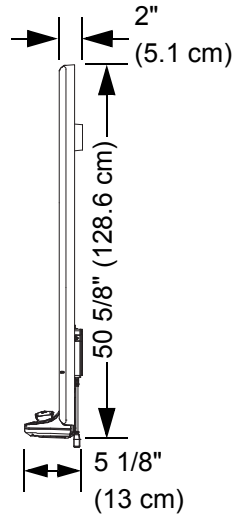

**Wall-Mounted
Front View**

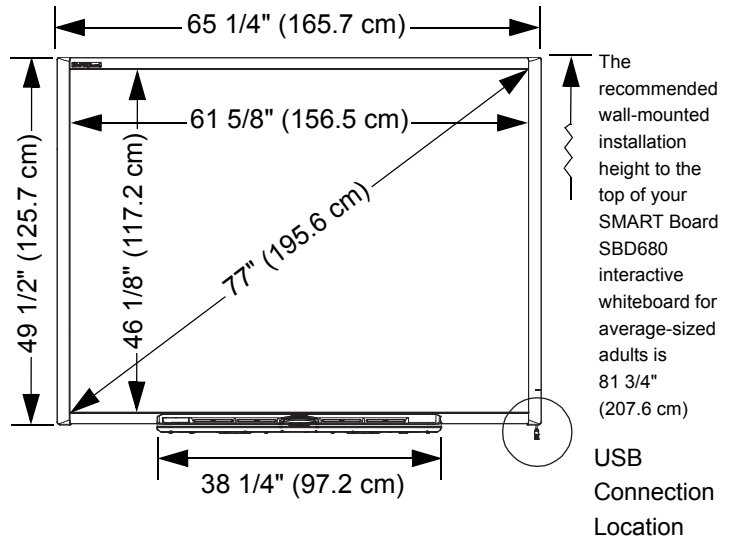

**Floor Stand-Mounted Side View
(Lowest Position)**

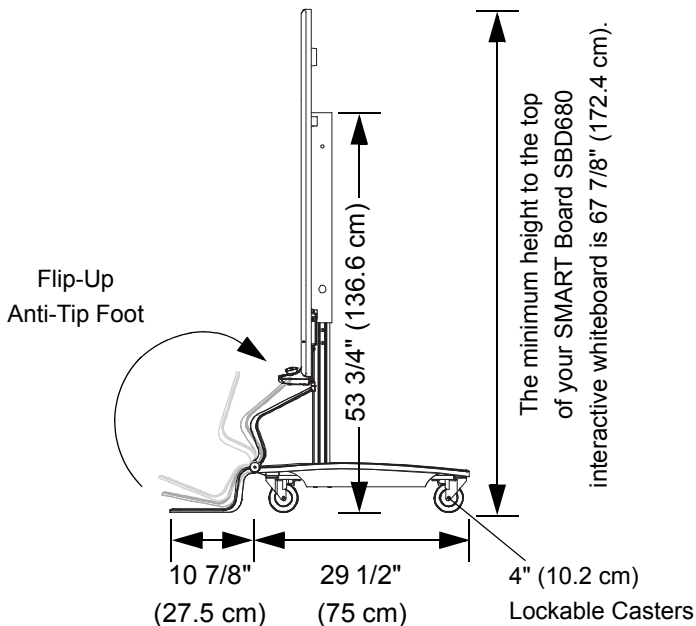

**Floor Stand-Mounted Back View
(Highest Position)**

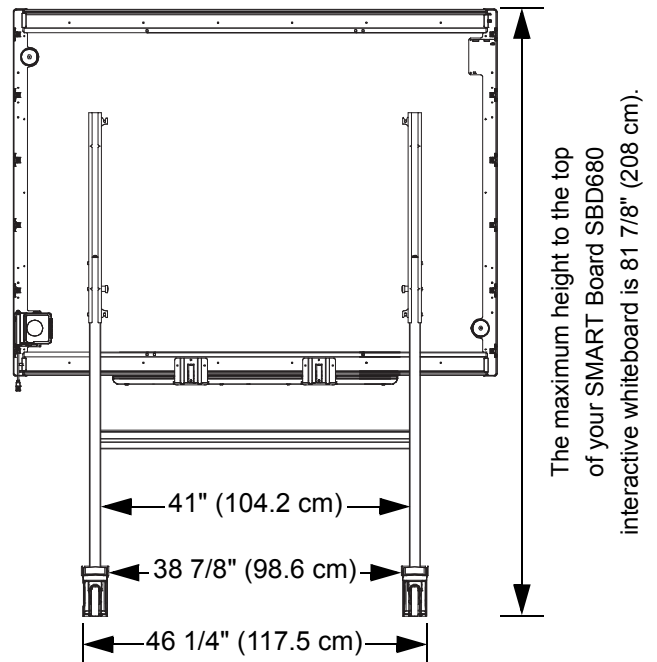

All dimensions +/- 1/8" (0.3 cm).

www.smarttech.com/support www.smarttech.com/contactsupport
Support +1.403.228.5940 or Toll Free 1.866.518.6791 (U.S./Canada)

SMART™

©2009 SMART Technologies ULC. All rights reserved. SMART Board, GoWire, the SMART logo and smarttech are trademarks or registered trademarks of SMART Technologies ULC in the U.S. and/or other countries. Bluetooth is a trademark owned by Bluetooth SIG, Inc. and is used by SMART Technologies ULC under license. All other third-party product and company names may be trademarks of their respective owners. Patent No. US5448263; US6141000; US6320597; US6326954; US6337681; US6741267, US6747636; US7151533; US7289113; US7499033; CA2058219; and CA2252302. Other patents pending. Contents are subject to change without notice. 08/2009.